

UDC 62-272

## METHOD FOR DETERMINING THE PARAMETERS OF SPRINGS OF COMBINED SPRING SETS

PhD (Tech.) Yevhenii Romanovych, PhD (Tech.) Oleksii Lobiak, PhD (Tech.) Andrii Kravets, PhD (Tech.) Andrii Yevtushenko, PhD (Tech.) Yevhenii Povorozhenko, PhD (Tech.) Anna Kravets

## МЕТОД ВИЗНАЧЕННЯ ПАРАМЕТРІВ ПРУЖИН ПРУЖИННИХ КОМПЛЕКТІВ КОМБІНОВАНОГО ТИПУ

Кандидати техн. наук Є. В. Романович, О. В. Лобяк, А. М. Кравець, А. В. Євтушенко, Є. В. Повороженко, А. Л. Кравець

DOI: <https://doi.org/10.18664/1994-7852.201.2022.267776>



**Abstract.** *Devices that may be affected by vibration loads from rolling stock passing nearby include automation, signalling and blocking system equipment. Therefore, the currently applicable regulatory document requires testing of this equipment, including vibration testing. Therefore, parameters of vibration protection systems of this equipment should be evaluated at the design stage. Spring sets of vibration protection systems often contain compression springs located in different directions. Accordingly, some of the springs of the spring set work along their longitudinal axis, while some springs work across the longitudinal axis, which makes it possible to call such sets combined spring sets. The literature provides dependences for determining the stiffness of compression springs that are exposed to vibration both along and across their longitudinal axis. However, determining the stiffness of combined spring sets is rather difficult. Therefore, in this paper, we consider a method for determining the required stiffness of combined spring sets and also propose a method for determining the parameters of springs of combined spring sets during designing vibration protection systems for equipment located near railway tracks.*

**Keywords:** *spring, movement, acceleration, stiffness, vibration protection.*

**Анотація.** *Залізничний транспорт є джерелом вібраційних впливів, що передаються через ґрунт на розташовані поблизу конструкції та споруди. Ця вібрація може впливати на технічний стан цих споруд. До пристроїв, на працездатність яких може впливати вібраційне навантаження від рухомого складу, що проходить поруч, належить обладнання систем автоматики, сигналізації та блокування. Чинними нормативними документами передбачені випробування цього обладнання, у тому числі на вібраційні навантаження. Але випробування натурних зразків є тривалим і дорогим процесом, тому виникає необхідність ще на стадії проектування оцінити параметри систем вібраційного захисту цього обладнання.*

*Для зменшення впливу вібрації на електронні та електротехнічні компоненти в пристроях залізничної автоматики, сигналізації та блокування передбачаються системи вібраційного захисту, в основі яких є пружинні комплекти. Такі комплекти часто містять пружини стиснення, розташовані в різних напрямках. Відповідно частина пружин пружинного комплекту працює вздовж своєї поздовжньої осі, а частина - поперек, що дозволяє називати такі пружинні комплекти комбінованими. У літературі наводяться залежності для визначення жорсткості пружин стиснення, які сприймають вібраційні навантаження як вздовж, так і поперек своєї поздовжньої осі. Але під час визначення жорсткості пружинних комплектів комбінованого типу виникають певні труднощі.*

Тому в цій роботі розглянутий спосіб визначення потрібної жорсткості пружинних комплектів комбінованого типу, а також запропонований метод визначення параметрів пружин комбінованих пружинних комплектів на стадії проектування систем вібраційного захисту обладнання, розташованого поблизу залізничних колій.

Сутність запропонованого методу полягає в такому. Шафа керування розглядається як одномасова коливальна система, граничні амплітудно-частотні характеристики якої задані чинними нормативними документами. Це дозволяє визначити необхідну жорсткість пружинного комплекту системи вібраційного захисту. Далі, використовуючи відомі залежності, стає можливим визначення характеристик пружин, з яких складається пружинний комплект. Але при використанні цих залежностей на стадії проектування виникає забагато невідомих показників. У цій роботі наводяться рекомендації щодо обґрунтованого призначення значень цих показників.

Результати досліджень, наведених у цій роботі, були використані на стадії проектування апаратури мікропроцесорної автоматичної системи переїзної сигналізації «ШАПС-М» виробництва ТОВ «АТ СИГНАЛ» (Україна) для визначення показників системи вібраційного захисту цієї апаратури.

**Ключові слова:** пружини стиснення, вібраційний захист залізничного обладнання, комбіновані пружинні комплекти, жорсткість пружин.

**Introduction.** Railway transport is a source of vibration effects transmitted through the ground to nearby structures and constructions. This vibration can affect the technical condition of these structures. The main source of vibration during the movement of railway rolling stock is wheel impacts at the joints and irregularities of the rails [1].

Structures located near railway tracks that may be affected by vibration loads from rolling stock passing nearby include automation, signalling and blocking system equipment. Automation, signalling and blocking equipment, which is installed in the Ukrainian

railway transport, must meet the requirements of the standard of Ukrzaliznytsya Joint-Stock Company [2], which defines, among others, requirements for the levels of vibration loads that this equipment must withstand, as well as monitoring methods for such loads.

For example, the controlling equipment of an automatic level crossing signaling system is placed in a metal cabinet (Figure 1). This cabinet is installed at a distance of no more than 5 m from the railway track. Thus, vibrations from the passing rolling stock are transmitted through the ground to this cabinet.

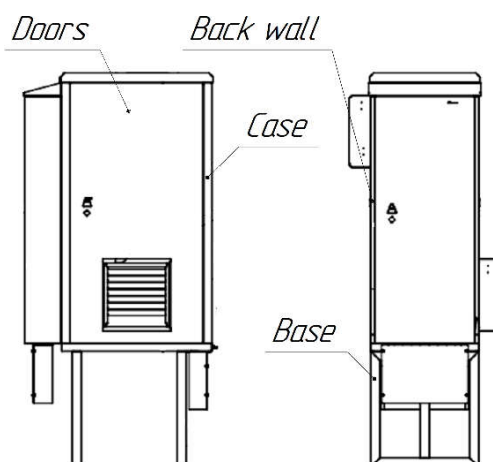

Fig. 1. Control cabinet of the automatic level crossing signaling equipment

To reduce the impact of vibration on the electronic and electrical components of the control system, this equipment is installed on a spring-loaded frame (Figure 2). The spring set of the cabinet frame most often includes cylindrical springs, some of which are located with their axes directed along the Z-axis, and some with their axes directed along the X-axis (Figure 2). Thus, under the action of vibration load along the X-axis, Springs 2 take up this load with their transverse stiffness, while Springs 3 take it up with their longitudinal

stiffness; under the action of vibration load along the Z-axis, Springs 2 take up this load with their longitudinal stiffness, while Springs 3 take the load with their transverse stiffness; under the action of vibration load along the Y-axis, Springs 2 and 3 take up this load with their transverse stiffness. Such a spring set can be called a combined: in such a set, one part of the springs takes up the vibration load with its longitudinal axis, while the other - with its transverse axis.

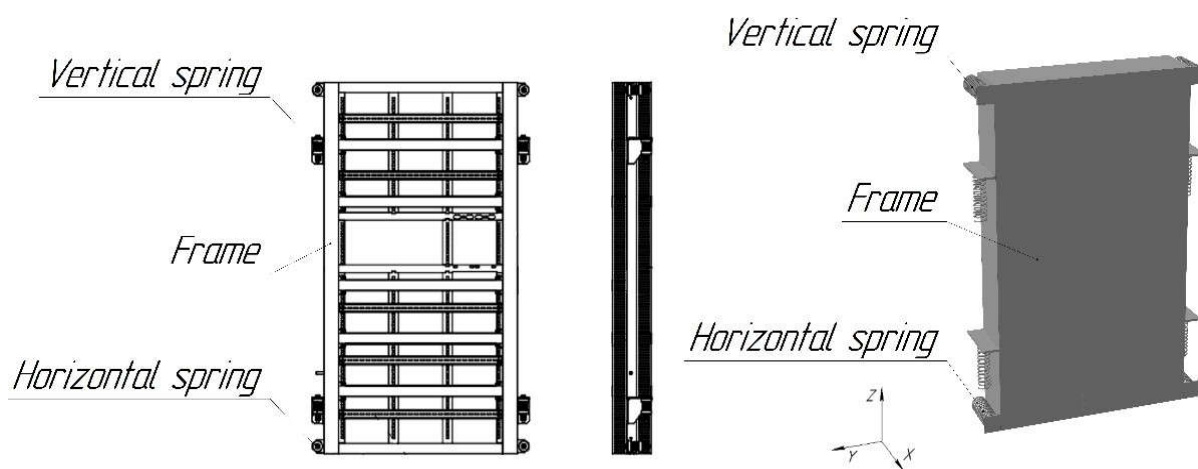

Fig. 2. Spring-loaded frame for installation of control equipment of the automatic level crossing signaling system

**The purpose and objectives of the study.** The purpose of this article is to develop a new approach to the calculation of spring protection systems for equipment subject to vibration.

To realize this goal, it is necessary to develop a new method of determining the required stiffness of spring sets of the combined type. In practice, check the effectiveness and accuracy of this method for determining the spring parameters of spring sets for vibration protection of railway equipment.

**The main part of research.** The currently applicable regulatory document [2] sets the maximum values of vibration loads to which railway automation products must to be

exposed during acceptance tests. Table 1 shows an example of the test vibration loads required by [2] for the housing of the control cabinet of the automatic level crossing signaling system and the maximum permissible vibration values that can be transmitted to the frame of this cabinet with the equipment installed on it.

I.e., if the constraining forces frequency is less than the transition frequency ( $f \leq f_t$ ), then the controlled parameter is the amplitude of vibrational displacements, and if the frequency of the constraining force is greater than the transition frequency ( $f \geq f_t$ ), then the controlled parameter is the amplitude of vibration accelerations.

Table 1

Vibration test loads of the control cabinet housing and maximum permissible vibration values that can be transmitted to the frame of this cabinet

Constraining force frequency interval $f$ , Hz	Vibration test loads of the control cabinet housing		Maximum permissible vibration values that can be transmitted to the control cabinet frame	
	displacement amplitude $A_0$ , mm	acceleration amplitude $A''_0$ , $m/s^2$	displacement amplitude $A$ , mm	acceleration amplitude $A''$ , $m/s^2$
from 5 to 20	1.5	-	0.5	-
from 20 to 80	-	6.0	-	2.3

Note: transition frequency  $f_t = 20$  Hz

**Simulation of forced vibrations of the cabinet frame**

When vibration effects on the cabinet frame with equipment installed on it is simulated, the provisions of the theory of mechanical vibrations given in [3-7] are used. According to this theory, a design scheme was created (Figure 3) and the following assumptions were made:

- the cabinet frame with the equipment installed on it was assumed as an absolutely rigid body, the mass of which is concentrated in its geometric center;
- constraining force applied in the center of mass of the cabinet frame;
- the springs of the spring kit are weightless and inertia free;
- the spring kit is friction-free, environmental resistance is absent.

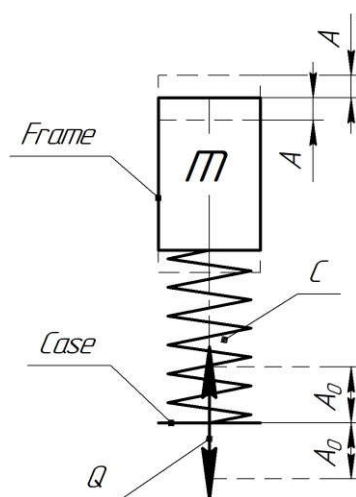

Fig 3. Design scheme of vibration effect on the cabinet frame

In accordance with the requirements of [2], constraining force  $Q$  changes along the sine curve. In this case, the differential equation of forced harmonic vibrations of the cabinet frame with the automatic level crossing signaling

equipment installed on it along the X, Y and Z axes (Figure 2) has the following form

$$m \cdot x'' + c_0 \cdot x = H \cdot \sin(\omega \cdot t). \quad (1)$$

According to [3-7], the solution of differential equation (1) will have the form

$$x = A \cdot \sin(\omega \cdot t). \quad (2)$$

Since acceleration is the second derivative of displacement, the formula for determining the acceleration of the cabinet frame with the equipment installed on it will take the following form

$$x'' = -\omega^2 \cdot A \cdot \sin(\omega \cdot t). \quad (3)$$

In accordance with [3-7], we determine the amplitudes:

- of displacement of the cabinet frame with the equipment installed on it

$$A = \frac{H}{c - \omega^2 \cdot m}; \quad (4)$$

- acceleration of the cabinet frame with equipment installed on it

$$A'' = -\frac{\omega^2 \cdot H}{c - \omega^2 \cdot m}. \quad (5)$$

To find the amplitude of the constraining force, Hooke's law can be used [8, 9]

$$F = -c \cdot \Delta x. \quad (6)$$

According to [2], for the case where the frequency of the compressive force is less than the transition frequency ( $f \leq f_t$ ), the amplitude of forced vibrations of the control cabinet housing is known  $A_0$ . Then the amplitude of the constraining force is determined by the formula

$$H = -c \cdot A_0. \quad (7)$$

Also, in accordance with [3-7], the circular frequency of the constraining force is determined by the formula

$$\omega = 2 \cdot \pi \cdot f. \quad (8)$$

Let us substitute formulas (7) and (8) into formula (4) to finally obtain a formula for

determining the amplitude of displacements of the cabinet frame with the equipment installed on it

$$A = \frac{-c \cdot A_0}{c - 4 \cdot \pi^2 \cdot f^2 \cdot m}. \quad (9)$$

According to [2], for the case where the frequency of the compressive force is greater than the transition frequency ( $f \geq f_t$ ), the amplitude of accelerations of forced vibrations of the control cabinet housing is known  $A''_0$ . Then the amplitude of the constraining force is determined by the formula

$$H = \frac{c \cdot A''_0}{\omega^2}. \quad (10)$$

We substitute formulas (8) and (10) into formula (5) to finally obtain a formula for determining the acceleration amplitude of the cabinet frame with the equipment installed on it

$$A'' = \frac{-c \cdot A''_0}{c - 4 \cdot \pi^2 \cdot f^2 \cdot m}. \quad (11)$$

### Calculation of the required stiffness of the spring set

Since the values of the amplitudes of vibration displacements and accelerations of the body and frame of the control cabinet are set [2], then the value of the required stiffness of the spring set can be determined using formulas (9) and (11)

$$c = \frac{4 \cdot \pi^2 \cdot f^2 \cdot m \cdot A}{A_0 + A}, \quad (12)$$

$$c = \frac{4 \cdot \pi^2 \cdot f^2 \cdot m \cdot A''}{A''_0 + A''}. \quad (13)$$

Taking into account the requirements of the current regulatory document [2], the required stiffness of the spring set should be determined in two frequency ranges of the coercive force:

Frequency range 1. From the minimum frequency of the coercive force  $f_{min}$  to the

transition frequency  $f_t$  – according to the formula (12);

Frequency range 2. From the transition frequency  $f_t$  to the maximum  $f_{max}$  – according to the formula (13).

Since the requirements of the applicable regulatory document [2] on vibration protection are the same for all directions of vibration, determining the required stiffness of the spring

set for each of the axes (Figure 2) of forced oscillations is not necessary.

For example, Table 2 shows the results of calculations of the required stiffness of the spring set of the control cabinet of the automatic crossing alarm system at minimum  $m_{min}$  and maximum  $m_{max}$  weights of the frame with the installed equipment. The rest of the source data are taken from Table 1.

Table 2

The results of calculations of the required stiffness of the spring set of the control cabinet of the automatic crossing alarm system

Weight of the frame with the installed instruments $m$ , kg	Required stiffness of the spring set $c$ , kN/m			
	Frequency range 1		Frequency range 2	
	$f_{min} = 5$ Hz	$f_t = 20$ Hz	$f_t = 20$ Hz	$f_{max} = 80$
$m_{min} = 76$ kg	18.8	300.0	332.6	5321.1
$m_{max} = 118$ kg	29.1	465.8	516.4	8261.7

The least of the received values should be accepted as the calculated value, in our case the required stiffness of a spring set was розрахункового значення  $c = 18.8$  kN.

**Determining stiffness of springs of the combined spring set.**

In general, the stiffness of a combined spring set along the corresponding axis of application of the vibration load (Figure 2) can be defined as the total stiffness of springs operating in the longitudinal and transverse directions

$$c = \sum c_l + \sum c_t. \tag{14}$$

In view of technological and economic considerations, developers of vibration protection systems often try to ensure that all springs of the spring set are the same. Let us consider this variant, in which all the springs of the spring set are the same. For example, when the compressive force is directed along the Z-axis (Figure 2), the stiffness of a combined spring set can be determined as follows

$$c = c_l \cdot n_l + c_t \cdot n_t. \tag{15}$$

The longitudinal stiffness of a spring is determined by the formula given in [10, 11]

$$c_l = \frac{G \cdot d^4}{8 \cdot D^3 \cdot n \cdot \psi}. \tag{16}$$

According to [10], the coefficient depends on the spring index

$$\psi = \begin{cases} 1 - \frac{3}{16 \cdot i^2} & \text{at } i \leq 5, \\ 1 & \text{at } i > 5 \end{cases}, \tag{17}$$

where  $i$  - spring index.

According to [10], the spring index is defined as the ratio of the average spring diameter to the diameter of the bar from which the spring is made

$$i = \frac{D}{d} \tag{18}$$

According to [10], the transverse stiffness of a spring is determined by the formula

$$C_t = \frac{3 \cdot E \cdot d^4}{8 \cdot D \cdot n \cdot [h_0^2 \cdot (2 + \mu) + 3 \cdot D^2]} \quad (19)$$

Let us substitute formulas (16) and (19) into formula (15). In this case, the formula for determining the stiffness of the combined spring set will take the following form, N/m

$$c = \frac{G \cdot n \cdot d^4}{8 \cdot D^3 \cdot n \cdot \psi} + \frac{3 \cdot E \cdot n \cdot d^4}{8 \cdot D \cdot n \cdot [h_0^2 \cdot (2 + \mu) + 3 \cdot D^2]} \quad (20)$$

Formula (20) requires the stiffness of the spring set  $c$  is known, it can be defined from formulas (12) and (13). The diameter of wire from which the spring is made  $d$ , average spring diameter  $D$ , spring height in the free state  $h_0$ , number of active coils of the spring  $n$ , as well as the coefficient  $\psi$ , which depends on the spring index  $i$  are unknown. In preliminary calculations of the parameters of springs of the spring set, the coefficient that depends on the spring index can be ignored by assigning  $\psi = 1$  [12]. This allows us to somewhat simplify formula (20) by limiting the number of unknown quantities to four:  $d$ ,  $D$ ,  $n$  and  $h_0$

$$c = \frac{G \cdot n_l \cdot d^4}{8 \cdot D^3 \cdot n} + \frac{3 \cdot E \cdot n_t \cdot d^4}{8 \cdot D \cdot n \cdot [h_0^2 \cdot (2 + \mu) + 3 \cdot D^2]} \quad (21)$$

Hence, it is convenient to express the diameter of wire from which the spring is made

$$d = \sqrt[4]{\frac{8 \cdot n \cdot c}{\frac{G \cdot n_l}{D^3} + \frac{3 \cdot E \cdot n_t}{D \cdot [h_0^2 \cdot (2 + \mu) + 3 \cdot D^2]}}} \quad (22)$$

In this formula the average spring diameter  $D$ , spring height in the free state  $h_0$ , number of active coils of the spring  $n$  are unknown.

Also, when designing device elements, it can be useful to estimate the height of the springs of the spring set

$$h_0 = \sqrt{\frac{3 \cdot D^2}{2 + \mu} \cdot \left( \frac{E \cdot n_t \cdot n \cdot d^4}{8 \cdot c \cdot n \cdot D^3 - G \cdot n_l \cdot d^4} \right)} \quad (23)$$

The source data in the calculations using formulas (22) and (23) are three values. For example, in formula (23) such values are the diameter of the wire from which the spring is made  $d$ , the mean diameter of the spring  $D$ , and the number of active coils of the spring  $N$ . Such amount of source data complicates the selection of this data. Then the minimum number of active coils of the spring  $N_{min}$  can be determined.

To simplify the selection of source data, let us consider formula (23). According to the rules of algebra [13] in formula (23), the expression under the sign of the square root cannot have a negative value. In this case, the expression  $(8 \cdot c \cdot N \cdot D^3 - G \cdot n_l \cdot d^4)$  must be at least zero

$$N_{min} \geq \frac{G \cdot n_l \cdot d^4}{8 \cdot c \cdot D^3} \quad (24)$$

To perform the calculation according to this formula, the diameter of the wire from which the spring is made  $d$  and the mean diameter of the spring  $D$  should be chosen. The outer diameter of the spring  $D_a$  is most commonly used to design a spring set. Then the mean diameter of the spring  $D$

$$D = D_a - d \quad (25)$$

In such case, formula (24) will have the form

$$N_{min} \geq \frac{G \cdot n_l \cdot d^4}{8 \cdot c \cdot (D_a - d)^3} \quad (26)$$

The obtained number of active coils of the spring  $N_{min}$  should be rounded up to the nearest whole number.

### Procedure for predetermination of parameters of the springs

Based on the above, we can recommend the following step-by-step procedure for pre-

determining the parameters of the springs of the spring set.

Step 1. After analyzing vibration loads on the device and selecting the design of the spring set, stiffness of the spring set is determined according to formulas (12) and (13). The lowest value among those calculated by these formulas should be chosen as the required stiffness of the spring set.

Step 2. For the sake of the design, the values of the diameter of the wire from which the spring is made  $d$ , and the outer diameter of the spring  $D_a$  should be pre-determined. It should be borne in mind that an increase in the diameter  $d$  of the wire from which the spring is made results in an increase in the stiffness of the spring, while an increase of the outer diameter of the spring results in a decrease in the stiffness of the spring.

Step 3. According to formula (26), the minimum number of active coils of the spring  $N_{min}$  should be calculated and the number of active coils of the spring  $N$  should be determined based on the condition  $N \geq N_{min}$ .

Step 4. According to formula (23), the height of the springs of the spring set is determined. To reduce the height of the spring, the number of active coils of the spring  $N$  should be increased. It should be borne in mind that too many active coils can lead to collisions of the coils under load, which is unacceptable.

Step 5. According to the relevant methods, which are not described herein, the strength and durability of the springs are determined.

Step 6. The final parameters of springs of the set are determined.

**Conclusions.** The proposed method reduces the duration and simplifies the complexity of the process of determining the parameters of the springs of combined spring sets. It is also easy to implement as software.

This method was tested to determine the parameters of individual springs of spring sets for vibration protection of the control equipment of the crossing alarm system and showed high efficiency and sufficient accuracy.

**List of symbols:**

X, Y, Z	axes along which forced oscillations occur
$f$	frequency of coercive force [Hz]
$f_t$	transition frequency [Hz]
$A_0$	amplitude of test displacements of the control cabinet body [m]
$A_0''$	amplitude of test accelerations of the control cabinet body [m/s <sup>2</sup> ]
$A$	maximum permissible amplitude of test displacements of the control cabinet frame with the installed crossing signaling equipment [m]
$A''$	maximum permissible amplitude of test accelerations of the control cabinet frame with the installed crossing signaling equipment [m/s <sup>2</sup> ]
$m$	mass of the control cabinet frame with the installed crossing signaling equipment [kg]
$c$	stiffness of the spring set [N/m]
$Q$	coercive force [N]
$x''$	acceleration of the frame of the cabinet with the installed on-board signaling equipment [m/s <sup>2</sup> ]
$x$	displacement of the cabinet frame with the installed crossing signaling equipment [m]
$H$	amplitude of the coercive force [N]
$\omega$	circular frequency of the coercive force [radian/s]
$t$	time [s]
$F$	force [H]
$\Delta x$	spring elongation [m]
$f_{min}$	minimum test frequency of the coercive force [Hz]
$f_{max}$	maximum test frequency of the coercive force [Hz]
$m_{min}$	minimum mass of the frame with the installed crossing signaling equipment [kg]
$m_{max}$	maximum mass of the frame with the installed crossing signaling equipment [kg]
$\sum c_l$	total stiffness of springs that take vibration load along its longitudinal axis [N/m]
$\sum c_t$	total stiffness of springs that take vibration load across their longitudinal axis [N/m]



$c_l$	longitudinal spring stiffness [N/m]	$\psi$	coefficient depending on the spring index
$n_l$	number of springs that receive vibration load along their axis [pcs]	$i$	spring index
$c_t$	transverse spring stiffness [N/m]	$E$	modulus of normal elasticity of spring material [Pa]
$n_t$	number of springs that take vibration load across their axis [pcs]	$h_0$	spring height in free state [m]
$G$	shear modulus (modulus of rigidity) of spring material [Pa]	$\mu$	ratio of transverse strain of the spring material (Poisson's ratio)
$d$	spring wire diameter [m]	$N_{min}$	minimum number of active coils of the spring [pcs.]
$D$	mean spring diameter [m]	$D_a$	outer diameter of the spring [m].
$N$	number of active coils of the spring [pcs]		

### References

1. Bobin E. V. Bor'ba s proizvodstvennym shumom i vibraciej na zheleznodorozhnom transporte. Publishing house «Transport», Moscow, 1967. 302 p.
2. SOU 45.020-00034045-002:2006. Railway automation, telemechanics and communications products. General technical conditions. Official edition. The State Administration of Railroad Transport of Ukraine «Ukrzaliznytsya», Kyiv, 2007. 187 p.
3. Timoshenko S., Young D. H., Weaver W. Jr. Vibration problems in engineering. John Willey & Sons, New York, Chichester, Brisbane, Toronto, Singapore, 1991. 472 p.
4. S. Graham Kelly. Mechanical Vibrations. Theory and Applications. Cengage Learning, 2011. 878 p.
5. Baev V. C. Theory of vibrations. Second edition. Publishing house «Urayt», Moscow, 2018. 348 p.
6. Vulfson I. I. A short course in the theory of mechanical oscillations. Library of the journal «Bulletin of Scientific and Technical Development», Moscow, 2017. 241 p.
7. Panovko Ya. G. Vvedenie v teoriyu mehanicheskikh kolebaniy. Third edition. Publishing house «Nauka», Moscow, 1991. 256 p.
8. Novozhilov V. V. Theory of elasticity. Publishing house «Polytechnic», St. Petersburg, 2012. 409 p.
9. Landau L. D., Lifshic E. M. Theory of elasticity. Fourth edition. Publishing house «Nauka», Moscow, 1987. 248 p.
10. GOST 34628-2019 Springs and spring assemblages of spring suspension of railway rolling stock. Methods of strength analysis at longitudinal and combined loading. Official edition. Publishing house «Standartinform», Moscow, 2020. 22 p.
11. Norms for the calculation and design of new and modernized railway cars of the Ministry of Railways of the 1520 mm gauge (non-self-propelled): Approved by the Ministry of Heavy and Transport Engineering of the USSR and the Ministry of Railways of the USSR. VNIIV-VNIIZhT, Moscow, 1983. 310 p.
12. Dunaev P. F., Lelikov O. P. Designing units and parts of machines. Thirteenth edition. Bauman Moscow State Technical University Publishing House, Moscow, 2017. 564 p.
13. Khoroshilova E. V. Elementary mathematics. Part 1: Number theory. Algebra. Moscow University Press, Moscow, 2010. 472 p.

Романович Євгеній Валентинович, кандидат технічних наук, доцент, доцент кафедри машинобудування та технічного сервісу машин, Український державний університет залізничного транспорту. Тел.: +38 (067) 427-47-70. E-mail: 0674274770@ukr.net . ORCID iD: 0000-0003-2555-5849.

Лобяк Олексій Вікторович, кандидат технічних наук, доцент, завідувач кафедри будівельної механіки та гідравліки, Український державний університет залізничного транспорту. Тел.: +38 (050) 805-90-93. E-mail: lobiak@ukr.net . ORCID iD: 0000-0002-9553-4245.

Кравець Андрій Михайлович, кандидат технічних наук, доцент, доцент кафедри машинобудування та технічного сервісу машин, Український державний університет залізничного транспорту. Тел.: +38 (050) 503-98-23. E-mail: kravets\_am@ukr.net . ORCID iD: 0000-0002-3251-6576.

Євтушенко Андрій Вікторович, кандидат технічних наук, доцент, доцент кафедри машинобудування та технічного сервісу машин, Український державний університет залізничного транспорту. Тел.: +38 (067) 385-62-94. E-mail: ave65@ukr.net . ORCID iD: 0000-0002-8575-3030.

Повороженко Євгеній Віталійович, кандидат технічних наук, ревізор з безпеки руху АТ «Укрзалізниця». Тел.: +38 (050) 302-57-02. E-mail: uto1993@ukr.net . ORCID iD 0000-0002-8310-618X.

Кравець Анна Леонідівна, кандидат технічних наук, доцент, доцент кафедри управління вантажною і комерційною роботою, Український державний університет залізничного транспорту. Тел.: +38 (098) 210-04-23. E-mail: anya.obukhova@gmail.com . ORCID iD: 0000-0003-1165-1960.

Romanovych Yevhenii, PhD (Tech.), Associate Professor, Department of Mechanical Engineering and Technical Service of Machines Ukrainian State University of Railway Transport. Tel.: +38 (067) 427-47-70. E-mail: 0674274770@ukr.net . ORCID iD: 0000-0003-2555-5849.

Lobiak Oleksii, PhD (Tech.), Associate Professor, Department of Building Mechanics and Hydraulics, Ukrainian State University of Railway Transport. Tel.: +38 (050) 805-90-93. E-mail: lobiak@ukr.net. ORCID iD: 0000-0002-9553-4245.

Kravets Andrii, PhD (Tech.), Associate Professor, Department of Mechanical Engineering and Technical Service of Machines, Ukrainian State University of Railway Transport. Tel.: +38 (050) 503-98-23. E-mail: kravets\_am@ukr.net . ORCID iD: 0000-0002-3251-6576.

Yevtushenko Andrii, PhD (Tech.), Associate Professor, Department of Mechanical Engineering and Technical Service of Machines, Ukrainian State University of Railway Transport. Tel.: +38 (067) 385-62-94. E-mail: ave65@ukr.net. ORCID iD: 0000-0002-8575-3030.

Povorozhenko Yevhenii, PhD (Tech.), Traffic safety auditor of JSC Ukrzaliznytsia. Tel.: +38 (050) 302-57-02. E-mail: uto1993@ukr.net. ORCID iD 0000-0002-8310-618X.

Kravets Anna, PhD (Tech.), Associate Professor, Department of Cargo and Commercial Work Management, Ukrainian State University of Railway Transport. Tel.: +38 (098) 210-04-23. E-mail: anya.obukhova@gmail.com . ORCID iD: 0000-0003-1165-1960.

Статтю прийнято 28.09.2022 р.